

PUBLICATION NUMBER AMM--010
November 2, 2008

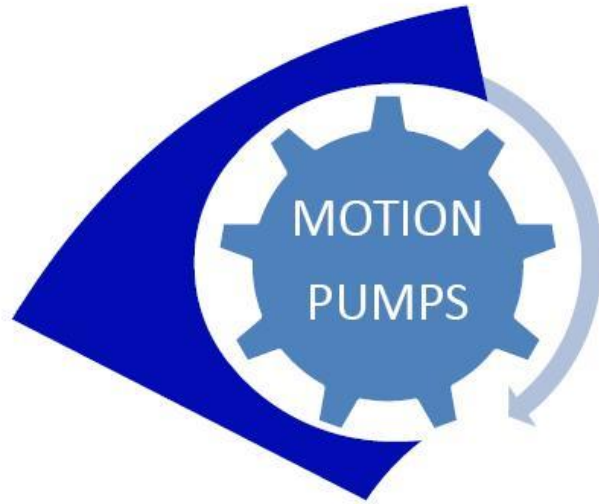

SELF-PRIMING CENTRIFUGAL PUMPS

APPLICATION MANUAL

**ML-2 ML-3 ML-4 ML-6 ML-8 ML-10 ML-12
MH-3 MH-4 MH-6**



INTRODUCTION

Thank You for purchasing Motion Pumps Self- Priming Centrifugal Pump. The Application Manual provides general information for installation and application. Therefore, it is the responsibility of the owner/installer of the pump to ensure that applications not addressed in this manual are performed **only** after establishing that neither operator safety nor pump integrity are compromised by the installation. Pumps and related equipment **must** be installed and operated according to all national, local and industry standards. If there are any questions regarding the pump which are not covered in this manual or in other literature accompanying the unit, please contact your Motion Pumps distributor or any of the following Motion Pumps offices:

USA

INTRA CORPORATION

10101 Dr.M.L.KingJr.St (9th St.)

Suit 240, St. Petersburg, FL 33716

Phone 727 565 1358

sales@motionpumps.com

Costa Rica

OPERACIONES INTERNACIONALES S.A.

100 mts. noroeste de la Rotonda de las Garantías Sociales, Zapote.

San José, Costa Rica.

Tels: (506) 2253-4343/ 2253-8783

Fax: (506) 2253-8358

interop@ice.co.cr



CONTENTS

Standard Centrifugal Pumps	4
Self Priming Pumps	5
How to read a pump performance curve Pages	7
Understanding pump applications	10
How to select the correct pump for the job	12
Pressure required at end of discharge line	12
Applications at Higher Elevations	13
Friction Loss in Pipe Fittings	15
Convert Chart	16
Capacity and flow chart	17
Theoretical Discharge of Nozzles	18
Where to use self priming pumps	19



STANDARD CENTRIFUGAL PUMPS

The simplest of all types, it has been in use since the 1700's. This pump operates on the centrifugal force principle, which can be seen in operation every time you drive your car on a wet road. The tire picks up water and throws it by centrifugal force against the fender.

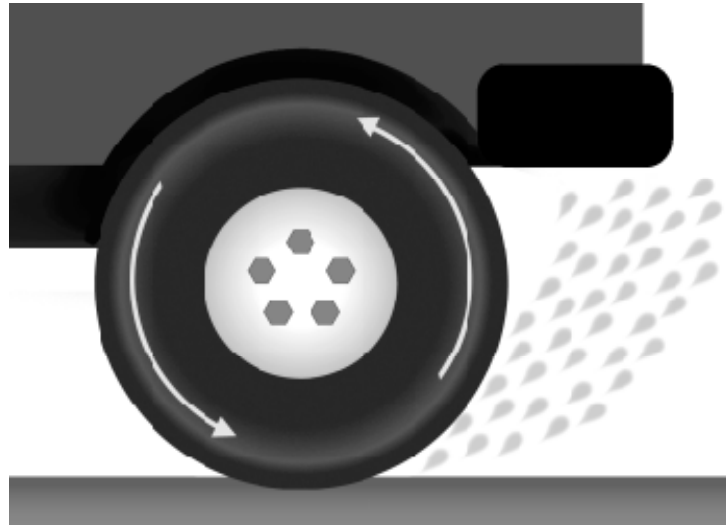

A centrifugal pump operates on the same principle except the tire is called an impeller and it has blades to move the water.

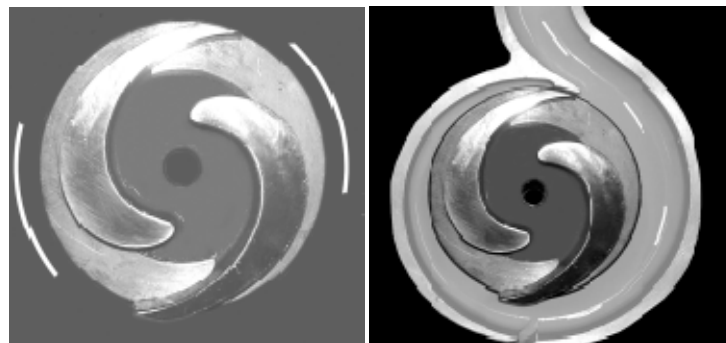

However, we can't have water going in all directions at once, so we direct it by means of a casing, or volute (pronounced va-loot) as it is called in the pump industry. The volute acts in the same manner as your car fender; it controls the water after it leaves the impeller.

This type of pump does a good job as long as the supply of liquid flows to the pump. Put the "Standard Centrifugal Pump" above the liquid, and problems can arise, as it does not have the ability to create a vacuum and prime itself. Should it pump the hole dry and air enter the pump, it will stop pumping and become airbound.

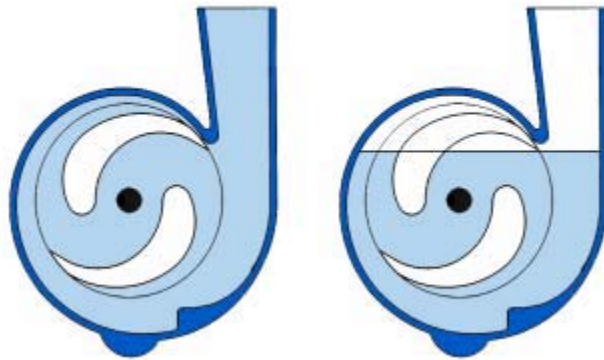

Accessory equipment must be used to evacuate entrained air within the pump, such as an eductor, a hand primer, etc. On construction jobs there is a need for a pump which has the ability to prime itself repeatedly, since the purpose of the pump is to keep the hole dry. As a result, the pump must lower the water below the strainer inlet time and time again, handling large amounts of air at the same time. A pump capable of repriming is a must.

SELF-PRIMING PUMPS

Here is how it works:

During the priming cycle, air enters the pump and mixes with water at the impeller. Water and air are discharged together by centrifugal action of the impeller into the water reservoir.

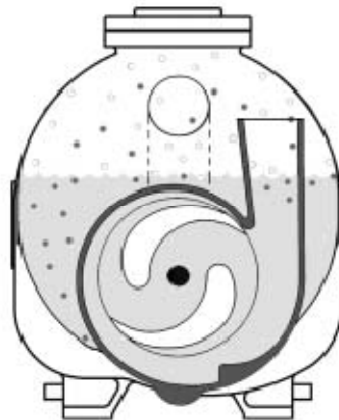

Once in the reservoir, the air and water mixture slows down from its former velocity, allowing air to escape out the discharge. Air-free water, now heavier than airladen water, flows by gravity back down into the impeller chamber, ready to mix with more air coming in the suction line.



Application Manual

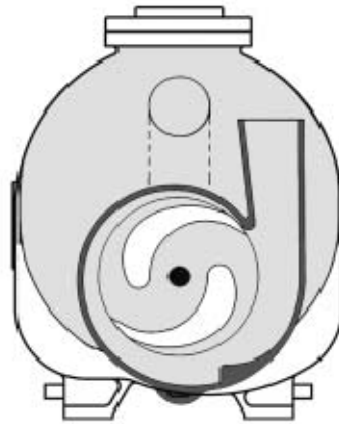

Once all air has been evacuated and a vacuum created in the suction line, atmospheric pressure forces water up into the suction line to the impeller, and pumping begins.

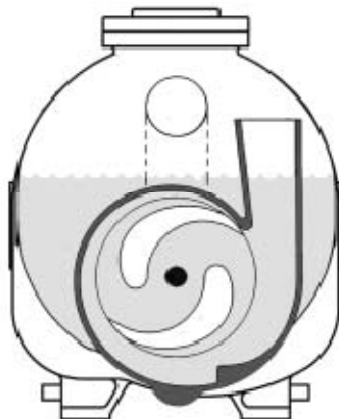

Recirculation of water within the pump stops when pumping begins. This type of pump differs from a standard centrifugal pump in that it has a water reservoir built into the unit which enables it to rid pump and suction line of air by recirculating water within the pump on priming cycle.

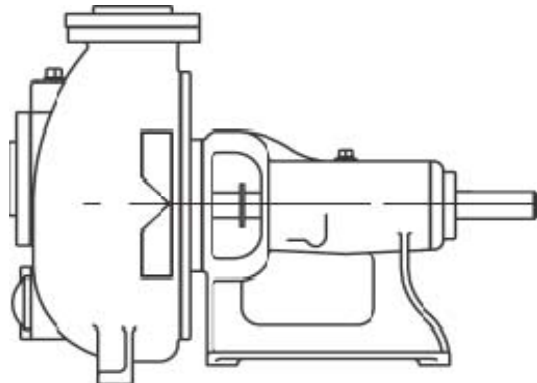



Motion Pumps ML-2

Centrifugal pumps may be manufactured in many different sizes and shapes. Impeller diameter controls the head or pressure; impeller blade controls the flow rate. Depending upon its intended use, an impeller may have two, three, or even six blades attached. As a rule, impellers designed to handle trashy water will have fewer blades with maximum width. Impellers for high head or pressure will have more blades of narrow width and may be enclosed on both sides of the blades. The limit of suction lift for any Motion Pumps is 26', use this for water at sea level, free pipe.

HOW TO READ PUMP PERFORMANCE CURVES

Curve "A"

This is a typical curve used to portray performance of a pump powered by a 5 HP gasoline engine-driven motor. Note, along the bottom is the capacity in U.S. Gallons per Minute. Along the left edge, amount of pressure the pump will develop is expressed in both pounds pressure and feet. These show the total head the pump will develop. Normally, the "feet" scale is used in figuring a contractor's pump job. Also on the curve are more lines. A solid line gives the performance of a unit at continuous duty (governed speed) operating conditions such as you would expect on a construction job. Lines marked 25', 20', 15', and 5' show maximum gallons per minute the pump is capable of delivering at various suction lifts (height of pump above water).

To read the curve, you may start at either left scale or bottom scale. Let's assume you desire to pump 100 GPM. Follow across the bottom GPM scale until you reach 100; then follow this line until you cross a heavy black line; then straight back to the left to the "feet" scale. What does this



Application Manual

tell you? Simply this: the pump is capable of pumping 100 GPM against a total head of approximately 68 feet, provided the pump is no more than 25 feet above water. Let us say total head is 60 feet. Start at the left on the “feet” scale, at the 60’ mark, until a heavy black line is reached; then straight down to the GPM scale.

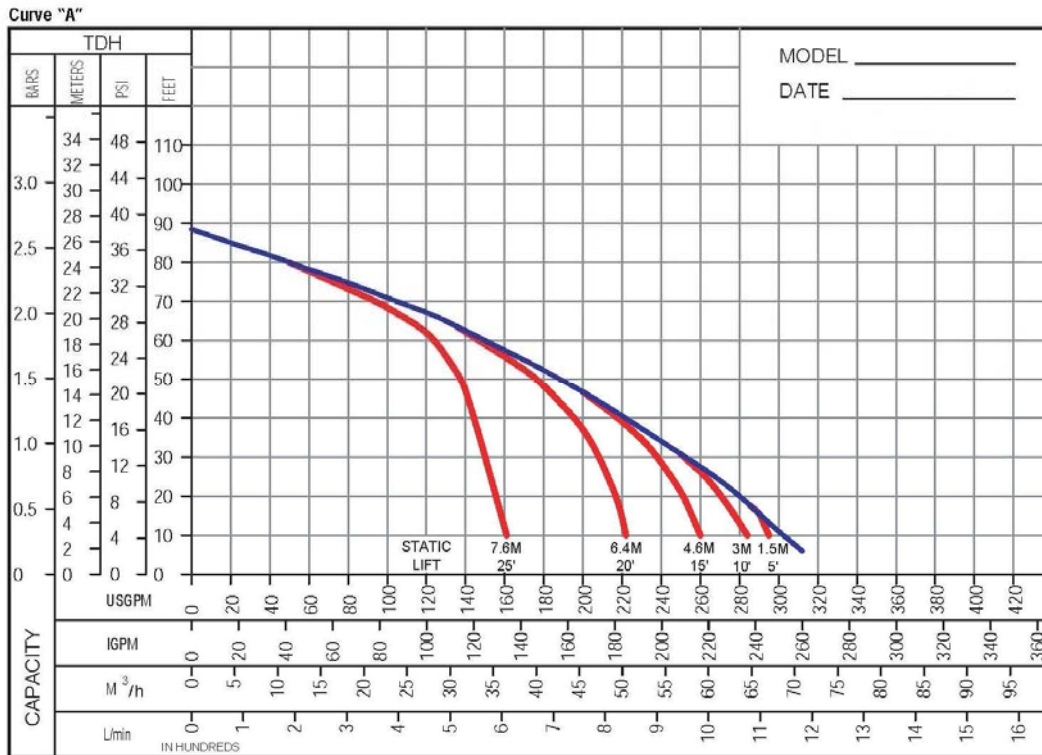

Result:

against a total head of 60 feet, the pump will deliver 150 GPM, provided the unit is no more than 20 feet above water. If the unit is 25 feet above water, the most you could expect would be about 125 GPM. Each pump has a performance curve. These graphs give the actual performance of a pump under different sets of conditions.

Curve "B"

There are more lines on this curve than on gasoline engine-driven pump curves. These extra lines are (1) RPM (Revolutions Per Minute), which illustrates performance at various speeds; (2) horsepower at various RPMs is also indicated and on Curve "B" is marked 1 to 6 BHP. This information is needed to pick the right size motor; (3) there is a chart which shows the maximum vertical distance that the pump will prime at various speeds marked maximum priming; (4) then there are lines marked static lift. Use these lines to determine a pump's suction lift. The result is maximum suction lift at which pump can be placed and still deliver desired gallons per minute.



Application Manual

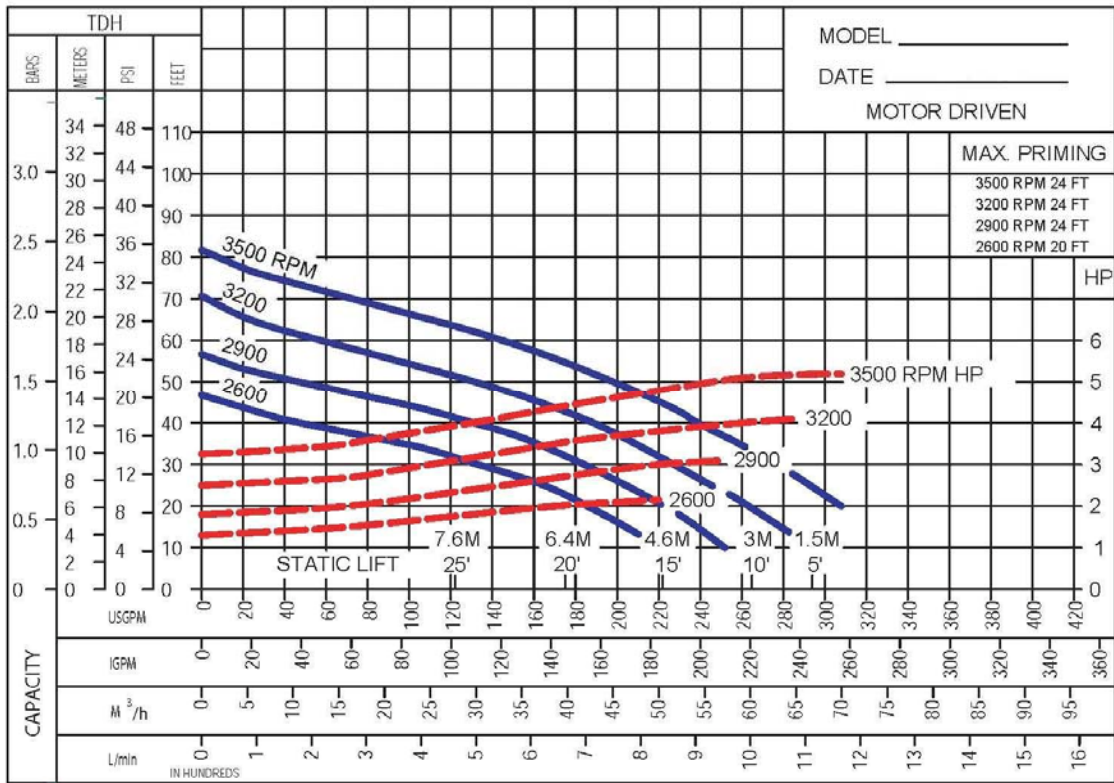

Curve "B"

Example: To pump 220 GPM, pump must be within 15 feet of water. Simple, isn't it? If you are operating a pump at higher elevations of 2,000' to 5,000' above sea level, refer to Page 13 for altitude deduction which must be taken into account.

An important item to remember in use of electric motor-driven pumps is the fact motors operate at a constant speed. Their RPM cannot be varied as can most gasoline or diesel engines.

Electric Motor Speeds (RPM)

60 Cycle	50 Cycle	25 Cycle
3450	2950	1450
1750	1450	725
1150	850	450

60 Cycle is the most prevalent in North America, with 50 Cycle the most common elsewhere. Using curve of pump B as an example, we could not expect this pump directly connected to a 3500 RPM motor to deliver as much as engine driven model A, which operates at a higher speed. To select the proper size motor, it is only necessary to refer to the RPM line at which pump is to be driven. Operation at 2900 RPM requires a 3 HP motor, as shown on the curve; and for operation at 3500 RPM, a 5 HP, 3450 RPM motor is needed. Note: 3500 RPM line starts at 3 HP



and goes up to 5 HP. This means you would overload a 3 HP motor, as it is necessary to use 5 HP.

Many times your customer will desire to use an electric motor driven pump. Curves depicting performance of these pumps are slightly different. Curve “B” illustrates these differences, for the same pump model as Curve “A”

UNDERSTANDING PUMP APPLICATIONS

Let us assume a contractor estimates water flow in a ditch he is digging at 200 GPM (gallons per minute). [See Table 2, page 17] The ditch is 5 feet deep and we must push water over an embankment 10 feet high and 80 feet away.

The contractor has estimated 200 GPM, but we know from past experience that not every person is a good judge of water flow and the contractor may run into additional water. So, to be on the safe side, we assume his maximum water requirement may be 220 GPM (10% more).

From the picture below, we see our customer has a suction lift (height of pump above the water) of 5 feet. He also has a discharge head (how high the water must be pushed vertically) of 10 feet.

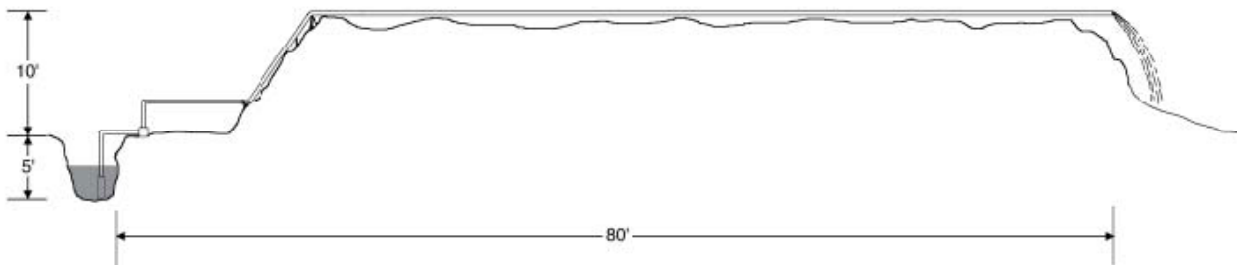

Next we must figure friction loss in total length of hose, piping and fittings:

Check with Table in page 15

1) Suction hose	10' (5' horizontal and 5' vertical)
2) Discharge piping	90' (80' horizontal and 10' vertical)
3) Strainer loss (equals 5 feet of pipe)	5'
4) 2-90° elbow (=7.7 feet of pipe each)	15.4'
4) 2-45° elbow (=3.6 feet of pipe each)	<u>7.2'</u>
Total length of pipe, hose, fittings	127.6' approx.= 128'

Next, we refer to Page 14 of this manual for the friction loss table. Here we find it is impractical to use smaller than 3” pipe or hose for 220 GPM. We note friction loss for 220 GPM through 3” pipe is 21.3 feet per 100 feet of hose. Since we have a total of 128 feet, we multiply 1.28 times 21.3 and find our total loss in hose is 27.3 feet.

We then add together the following:

Suction lift	5'
Discharge head	10'
Friction loss in hose	<u>27.3'</u>
Total head, including friction loss	42.3'

(Known as TDH, Total Dynamic Head)



Application Manual

Flow Map

Low Pressure Self Primer Pumps
ML-2 ML-3 ML-4 ML-6 ML-8 ML-10 ML-12

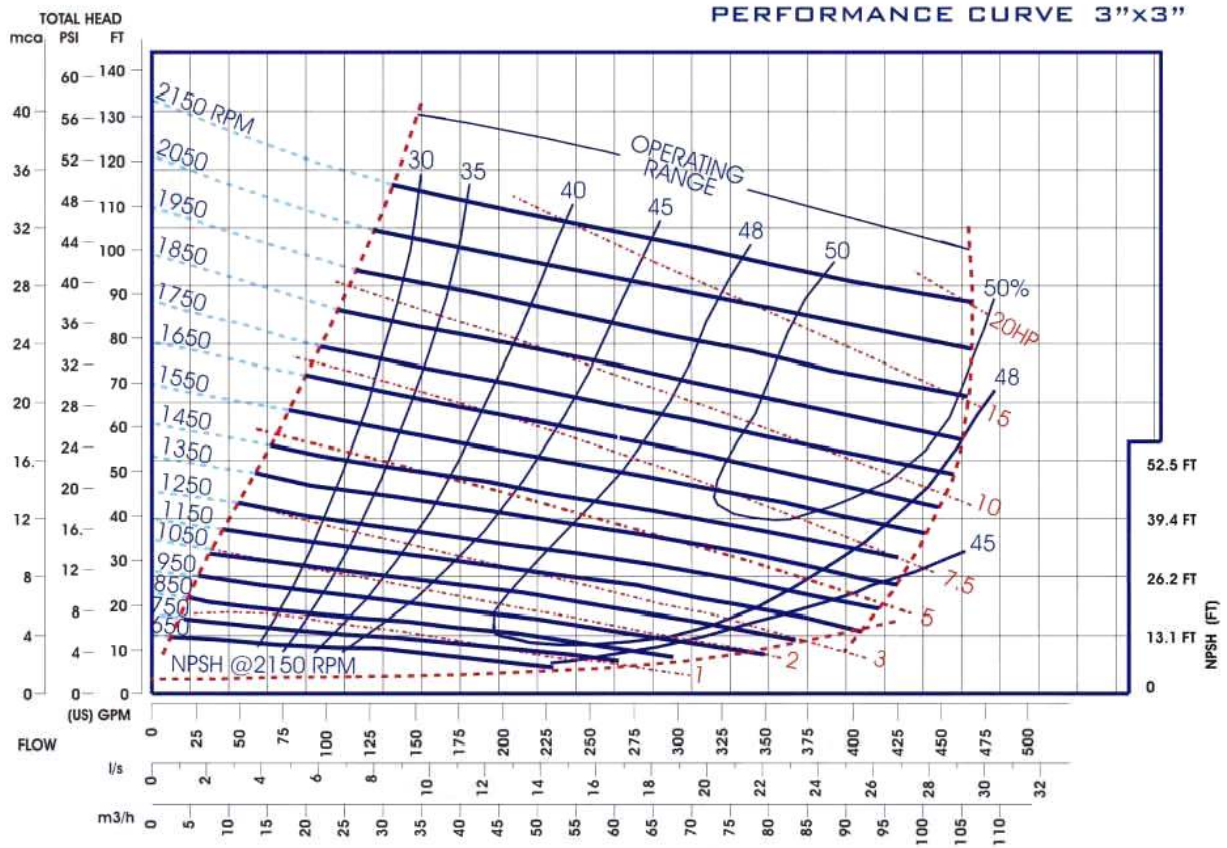
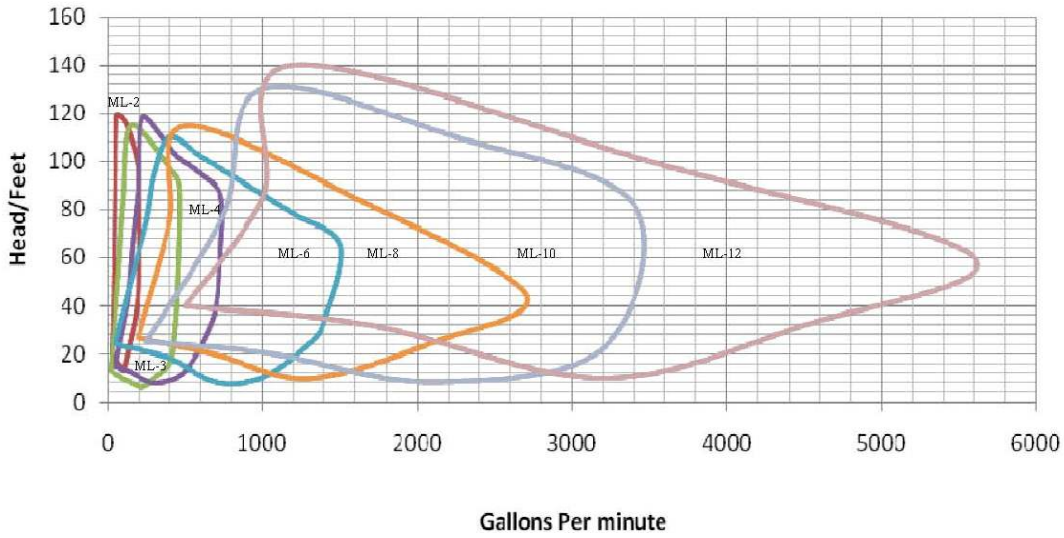



We must now find a pump which will give us 220 gallons per minute at a total head of 42.3 feet with the pump 10 feet above water.

Here we note our head condition of 42.3 feet is close to curve of the pump, at which point the pump will deliver 200 GPM when 10 feet above water. Therefore, we select a 3 inch pump that will need a 5HP motor, and the speed should be 1350 RPM. and an Efficiency of 45%

HOW TO SELECT THE RIGHT PUMP FOR THE JOB

Nine times out of ten, your customer will tell you he wants a 2-, 3- or 4-inch pump. Sometimes, however, your customer will ask you to figure the correct pump for a certain application. There are several things we must know before we attempt to select the proper pump:

- 1) How many gallons per minute are we going to pump?
- 2) How high is the pump above water?
- 3) How high must the water be pushed after it leaves the pump?
- 4) The total length of hose or pipe to be used.
- 5) Is water merely to be “dumped” at the end of the discharge run, or will it be used to perform work?

(See Special Conditions in Figuring Pump Applications)

PRESSURE REQUIRED AT END OF DISCHARGE LINE

Some applications, such as gravel washing, jetting, piling, and borrow pit sprinkling, require not only delivering water at a point some distance from the pump, but also supplying a certain amount of pressure at the end of the line. As an example, if 40 pounds of pressure were required for gravel washing in our illustration, this figure must be added to the result of our first four steps. It is easier to convert pounds pressure to feet of head, as we have used feet in figuring the application. From the table on Page 16 you will note 40 pounds is equal to approximately 92.3 feet of head.

Here is the result:

Total Head, including friction loss	42.3'
Pressure required at end of pipe	<u>92.3'</u>
New Total Head (TDH)	134.6'

We now need to make a new pump selection.

TO CONVERT	INTO	MULTIPLY BY
Pounds per sq. in.	Feet of Water	2.31
Feet (of water)	Pounds per sq. in.	0.433
Inches of Mercury	Feet of Water	1.133



APPLICATIONS AT HIGHER ELEVATIONS

Pump performance is calculated and plotted on all published data **at sea level**. At elevations of 1,000 feet and below, this data may generally safely be used, but at higher elevations both pump and engine lose output. Following is listed the loss in performance which may be expected compared with sea level performance:

ELEVATION	GPM	HEAD
2,000 Feet	-3%	-5%
4,000 Feet	-5%	-9%
6,000 Feet	-7%	-13%
8,000 Feet	-9%	-17%
10,000 Feet	-12%	-22%

Suction lift also suffers and adjustments must be made. The table below illustrates the equivalent suction lifts for various altitudes. Example: At 6,000 feet elevation, a pump must be placed with 6.9 feet of the water to deliver as much water in GPM (gallons per minute) as the same unit would at a 10-foot suction lift at sea level.

Elevation	Suction Lifts (in Feet)			
Sea Level	10.0	15.0	20.0	25.0
2,000 Feet	8.8	13.2	17.6	22.0
4,000 Feet	7.8	11.7	15.6	19.5
6,000 Feet	6.9	10.4	13.8	17.3
8,000 Feet	6.2	9.3	12.4	15.5
10,000 Feet	5.7	8.6	11.4	14.3

NOTE: All references to GPM in this booklet refer to US gallons per minute.

(1) To convert imperial gallons to US gallons, multiply imperial gallons by 1.2.

(2) To convert US gallons to imperial gallons, multiply US gallons by .83.

ENGINES, TOO, SUFFER FROM ALTITUDE

Most engines are rated by the manufacturer using 60 degrees Fahrenheit at sea level.

Deductions must be made from the rated horsepower as follows:

For each 1,000 feet above sea level, deduct 3.5%, and 1% for each 10 degrees Fahrenheit above 60 degrees.



Application Manual

FRICITION LOSS THROUGH 100' OF HOSE OR PIPE

Loss is given in feet of head. Based on Williams & Hazen formula using constant 100. Sizes of standard pipe in inches.

	.50" Pipe		.75" Pipe		1.0" Pipe		1.25" Pipe		1.50" Pipe		2.0" Pipe		2.50" Pipe		3" Pipe		4" Pipe		5" Pipe		6" Pipe				
U.S. Gallons per Minute	Vel. ft. per Sec.	Loss in feet	Vel. ft. per sec.	Loss in feet	Vel. ft. per sec.	Loss in feet	Vel. ft. per sec.	Loss in feet	Vel. ft. per sec.	Loss in feet	Vel. ft. per sec.	Loss in feet	Vel. ft. per sec.	Loss in feet	Vel. ft. per sec.	Loss in feet	Vel. ft. per sec.	Loss in feet	Vel. ft. per sec.	Loss in feet	Vel. ft. per sec.	Loss in feet	U.S. Gal Minute		
70							15.01	113.0	11.02	53.00	7.15	18.40	4.58	6.20	3.18	2.57	1.79	0.63	1.14	0.21	0.79	0.08	70		
75							16.06	129.0	1.80	60.00	7.66	20.90	4.91	7.10	3.33	3.00	1.91	0.73	1.22	0.24	0.85	0.10	75		
80							17.16	145.0	12.59	68.00	8.17	23.70	5.23	7.90	3.63	3.28	2.04	0.81	1.31	0.27	0.91	0.11	80		
85							18.21	163.8	13.38	75.00	8.68	26.50	5.56	8.10	3.78	3.54	2.17	0.91	1.39	0.31	0.96	0.12	85		
90							19.30	180.0	14.71	84.00	9.19	29.40	5.88	9.80	4.09	4.08	2.30	1.00	1.47	0.34	1.02	0.14	90		
95										14.95	93.00	9.70	32.60	6.21	10.80	4.22	4.33	2.42	1.12	1.55	0.38	1.08	0.15	95	
100										15.74	102.0	10.21	35.80	6.54	12.00	4.54	4.96	2.55	1.22	1.63	0.41	1.13	0.17	100	
110										17.31	122.00	11.23	42.90	7.18	14.50	5.00	6.00	2.81	1.46	1.79	0.49	1.25	0.21	110	
120										18.89	143.00	12.25	50.00	7.84	16.80	5.45	7.00	3.06	1.72	1.96	0.58	1.36	0.24	120	
130										20.46	166.00	13.28	58.00	8.48	18.70	5.91	8.10	3.31	1.97	2.12	0.67	1.47	0.27	130	
140	0.90	0.08								22.04	190.0	14.30	67.00	9.15	22.30	6.35	9.20	3.57	2.28	2.29	0.76	1.59	0.32	140	
150	0.96	0.09										15.32	76.00	9.81	25.50	6.82	10.50	3.82	2.62	2.45	0.88	1.70	0.36	150	
160	1.02	0.10										16.34	86.00	10.46	29.00	7.26	11.80	4.08	2.91	2.61	0.98	1.82	0.40	160	
170	1.08	0.11										17.36	96.00	11.11	34.10	7.71	13.30	4.33	3.26	2.77	1.08	1.92	0.45	170	
180	1.15	0.13										18.38	107.00	11.76	35.70	8.17	14.00	4.60	3.61	2.94	2.04	1.82	0.40	180	
190	1.21	0.14										19.40	118.00	12.42	39.60	8.63	15.50	4.84	4.01	3.10	1.35	2.16	0.55	190	
200	1.28	0.15										20.42	129.00	13.07	43.10	9.08	17.80	5.11	4.40	3.27	1.48	2.27	0.62	200	
220	1.40	0.18										22.47	154.00	14.38	52.00	9.99	21.30	5.62	5.20	3.59	1.77	2.50	0.73	220	
240	1.53	0.22	0.98	0.07								24.51	182.00	15.69	61.00	10.89	25.10	6.13	6.20	3.92	2.08	2.72	0.87	240	
260	1.66	0.25	1.06	0.08								26.55	211.00	16.99	70.00	11.80	29.10	6.64	7.20	4.25	2.41	2.95	1.00	260	
280	1.79	0.28	1.15	0.09								18.30	81.00	12.71	33.40	7.15	8.20	4.58	2.77	3.18	1.14	1.14	0.11	280	
300	1.91	0.32	1.22	0.11								19.61	92.00	13.62	38.00	7.66	9.30	4.90	3.14	3.40	1.32	1.32	0.13	300	
320	2.05	0.37	1.31	0.12								20.92	103.00	14.52	42.80	8.17	10.50	5.23	3.54	3.64	1.47	1.47	0.14	320	
340	2.18	0.41	1.39	0.14								22.22	116.00	15.43	47.60	8.68	11.70	5.54	3.91	3.84	1.62	1.62	0.16	340	
360	2.30	0.45	1.47	0.15										23.53	128.00	16.34	53.00	9.19	13.10	5.87	4.41	4.08	1.83	360	
380	2.43	0.50	1.55	0.17	1.08	.069								24.84	142.00	17.25	59.00	9.69	14.00	6.19	4.86	4.31	2.00	380	
400	2.60	0.54	1.63	0.19	1.14	.075								26.14	156.00	18.16	65.00	10.21	16.00	6.54	5.40	4.55	2.20	400	
450	2.92	0.68	1.84	0.23	1.28	0.95										20.40	78.00	11.49	19.80	.35	6.70	5.11	2.74	450	
500	3.19	0.82	2.04	0.28	1.42	.113	1.04	0.06								22.70	98.00	12.77	24.00	8.17	8.10	5.68	3.36	500	
550	3.52	0.97	2.24	0.33	1.59	.136	1.15	0.07								24.96	117.00	14.04	28.70	8.99	9.60	6.25	3.96	550	
600	3.84	1.16	2.45	0.39	1.70	.159	1.25	0.08									27.23	137.00	15.32	33.70	9.80	11.30	6.81	4.65	600
650	4.16	1.34	2.65	0.45	1.84	0.19	1.37	0.09										16.59	39.00	10.62	13.20	7.38	5.40	650	
700	4.46	1.54	2.86	0.52	1.99	0.22	1.46	0.10										17.87	44.90	11.44	15.10	7.95	6.21	700	
750	4.80	1.74	3.06	0.59	2.13	0.24	1.58	0.11										19.15	51.00	12.26	17.20	8.50	7.12	750	
800	5.10	1.97	3.26	0.66	2.27	0.27	1.67	0.13										20.42	57.00	13.07	19.40	9.08	7.96	800	
850	5.48	2.25	3.47	0.75	2.41	0.31	1.79	0.14	1.36	0.08								21.70	64.00	13.89	⌀			850	



FRICTION LOSS IN PIPE FITTINGS

(EXPRESSED AS EQUIVALENT LENGTHS OF STRAIGHT PIPE)

Nom Pipe Dia.	VALVES - FULL OPEN							ELLS						TEES		ENLGMT		CONTRN		
	GATE	PLUG	GLOB E	ANGL E	SWG CK	FOOT	SLUG SHUT OFF	45°	90°	L R 90°	TUBE-TURN				STR THRU	SIDE OUT'T	1/2	3/4	1/2	3/4
											STD.		L. R.							
											45°	90°	45°	90°						
1½"	.9	-	45	23	11	39	64	1.9	4.1	2.7	1.4	2.3	1.0	1.5	2.7	8.1	2.6	1.0	1.5	1.0
2"	1.1	6.0	58	29	14	47	66	2.4	5.2	3.5	1.9	3.0	1.3	2.0	3.5	10.4	3.2	1.2	1.8	1.2
2½"	1.3	6.5	69	35	16	55	75	2.9	6.2	4.2	2.4	3.8	1.6	2.5	4.2	12.4	3.8	1.3	2.2	1.3
3"	1.6	8	86	43	20	64	97	3.6	7.7	5.2	2.9	4.5	2.0	3.1	5.2	15.5	4.7	1.7	2.8	1.7
4"	2.1	17	113	57	26	71	134	4.7	10.2	6.8	3.8	6.0	2.6	4.1	6.8	20.3	6.2	2.3	3.6	2.3
6"	3.2	65	170	85	39	77	210	7.1	15.3	10.2	5.8	9.0	3.9	6.1	10.2	31	9.5	3.4	5.6	3.4
8"	4.3	110	-	112	52	79	270	9.4	20.2	13.4	7.7	12	5.2	8.1	13.4	40	13	4.5	7.4	4.5
10"	5.3	150	-	141	65	81	330	11.8	25.3	17	9.6	15	6.5	10.2	16.9	51	16	5.6	9.5	5.6
12"	6.4	-	-	168	77	83	410	14.1	30	20	11.5	18	7.8	12.2	20.2	61	19	6.8	11	6.8

FRICTION LOSS IN POUNDS PRESSURE

THROUGH ALUMINUM PIPE

GPM	Pipe Size	Length of Pipe in Feet							
		100'	200'	500'	1000'	2000'	3000'	4000'	5000'
50	2"	2.97	6.	15.	30.	60.	90.	119.	149.
	3"	.37	0.74	2.	4.	8.	12.	15.	19.
	4"	.09	0.18	1.	1.	2.	3.	4.	5.
100	2"	11.02	22.	56.	111.	221.	42.	56.	69.
	3"	1.38	3.	7.	14.	28.	10.	13.	16.
	4"	.32	0.64	2.	4.	7.			
150	2"	20.13	41.	101.	202.		85.	113.	141.
	3"	2.82	6.	15.	29.	57.	21.	28.	35.
	4"	.69	2.	4.	7.	14.			
200	3"	5.13	11.	26.	52.	103.	154.	206.	257.
	4"	1.21	3.	7.	13.	25.	37.	49.	61.
	6"	.16	0.32	1.	2.	4.	5.	7.	8.
300	3"	11.05	22.	56.	111.	221.	332.		
	4"	2.60	6.	13.	26.	52.	78.	104.	130.
	6"	.34	0.68	2.	4.	7.	11.	14.	17.
400	4"	4.50	9.	23.	23.	90.	135.	180.	225.
	6"	.59	1.	3.	3.	12.	18.	24.	30.
	8"	.14	0.28	1.	1.	3.	5.	6.	7.
500	4"	6.83	14.	35.	35.	137.	205.	274.	342.
	6"	.89	2.	5.	5.	18.	27.	36.	45.
	8"	.22	0.44	2.	2.	5.	7.	9.	11.
600	4"	9.75	20.	49.	49.	195.	293.		
	6"	1.28	3.	7.	7.	26.	39.	52.	64.
	8"	.31	0.62	2.	2.	7.	10.	13.	16.
700	6"	1.70	4.	9.	9.	34.	51.	68.	85.
	8"	.42	1.	3.	3.	9.	13.	17.	21.
800	6"	2.18	5.	11.	11.	44.	66.	88.	109.
	8"	.54	1.	3.	3.	11.	17.	22.	27.
1000	6"	3.35	7.	17.	17.	67.	101.	134.	168.
	8"	.82	2.	5.	5.	17.	25.	33.	41.
1200	6"	4.72	10.	24.	24.	95.	142.	189.	236.
	8"	1.16	3.	6.	6.	24.	35.	47.	58.
1400	6"	6.36	13.	32.	32.	128.	191.	255.	318.
	8"	1.56	3.	8.	8.	32.	47.	63.	78.



TO CONVERT

POUNDS PRESSURE TO FEET OF HEAD		FEET OF HEAD TO POUNDS PRESSURE	
POUNDS PRESSURE (PSI)	FEET HEAD	FEET HEAD	POUNDS PRESSURE (PSI)
1	2.31	1	0.43
2	4.62	2	0.87
3	6.93	3	1.30
4	9.24	4	1.73
5	11.55	5	2.17
6	13.85	6	2.60
7	16.16	7	3.03
8	18.47	8	3.46
9	20.78	9	3.90
10	23.09	10	4.33
20	46.18	20	8.66
30	69.27	30	12.99
40	92.36	40	17.32
50	115.49	50	21.65
60	138.54	60	25.99
70	161.63	70	30.32
80	184.72	80	34.65
90	207.80	90	38.98
100	230.90	100	43.31
120	277.07	120	51.97
140	323.25	140	60.63
160	369.43	160	69.29
180	415.61	180	77.96
200	461.78	200	86.62
300	692.69	300	129.93
400	922.58	400	173.24
500	1154.48	500	216.55



CAPACITY AND FLOW CHART

Table One

Amount of water per foot in excavations

Diameter of Pool of Water	U.S. Gallons per Foot of Depth
1'	6
2'	24
3'	53
4'	94
5'	147
6'	212
7'	288
8'	376
9'	476
10'	587
15'	1320
20'	2350
25'	3672
30'	5275
35'	7200
40'	9500
45'	11900
50'	14700

Table Two

Approximate flow of streams in U.S. Gallons per minute (Stream flow rate: 1' per second)

Depth of Stream at Midpoint	Width of Stream in Feet			
	1	3	5	10
1"	14	43	72	144
2"	39	121	202	404
3"	71	221	370	740
4"	108	338	569	1139
5"	148	470	794	1588
6"	190	614	1040	2080
7"	244	771	1304	2608
8"		935	1582	3164
9"		1106	1879	3759
10"		1286	2196	4392
11"		1486	2542	5084
12"		1674	2866	5732
13"		1864	3204	6408
14"		2086	3592	7184
15"		2296	3968	7936
16"		2516	4360	8720
17"		2770	4788	9576
18"		2964	5160	10320
19"		3192	5576	11152

To estimate large areas of water, remember:
7 1/2 gallons = 1 cubic foot (1' x 1' x 1')

Example: Assume we have an area 500' by 750' covered with water to a depth of 3'
 $500 \times 750 \times 3 = 1,125,000$ cubic feet
 $1,125,000 \times 7.50 = 8,437,500$ gallons to be removed

If the water were to be removed at a rate of 1000 GPM, it would take 140 hours of continuous pumping to do the job.

From this, you can see it pays to take the time to estimate the amount of water to be pumped.



Application Manual

THEORETICAL DISCHARGE OF NOZZLES IN U.S. GALLONS PER MINUTE

HEAD		Velocity of Discharge in Feet per Second	DIAMETER OF NOZZLES IN INCHES								
Pounds	Feet		1/16	1/8	3/16	1/4	3/8	1/2	5/8	3/4	7/8
10	23.1	38.6	0.37	1.48	3.32	5.91	13.3	23.6	36.9	53.1	72.4
15	34.6	47.25	0.45	1.81	4.06	7.24	16.3	28.9	45.2	65.0	88.5
20	46.2	54.55	0.52	2.09	4.69	8.35	18.8	33.4	52.2	75.1	102
25	57.7	61.0	0.58	2.34	5.25	9.34	21.0	37.3	58.3	84.0	114
30	69.3	68.85	0.64	2.56	5.75	10.2	23.0	40.9	63.9	92.0	125
35	80.8	72.2	0.69	2.77	6.21	11.1	24.8	44.2	69.0	99.5	135
40	92.3	77.2	0.74	2.96	6.64	11.8	26.6	47.3	73.8	106	145
45	103.9	81.8	0.78	3.13	7.03	12.5	28.2	50.1	78.2	113	153
50	115.5	86.25	0.83	3.30	7.41	13.2	29.7	52.8	82.5	119	162
55	127.0	90.4	0.87	3.46	7.77	13.8	31.1	55.3	86.4	125	169
60	138.6	94.5	0.90	3.62	8.12	14.5	32.5	57.8	90.4	130	177
65	150.1	98.3	0.94	3.77	8.45	15.1	33.8	60.2	94.0	136	184
70	161.7	102.1	0.98	3.91	8.78	15.7	35.2	62.5	97.7	141	191
75	173.2	105.7	1.01	4.05	9.09	16.2	36.4	64.7	101	146	193
80	184.8	109.1	1.05	4.18	9.39	16.7	37.6	66.8	104	150	205
85	196.3	112.5	1.06	4.31	9.67	17.3	38.8	68.9	108	155	211
90	207.9	115.8	1.11	4.43	9.95	17.7	39.9	70.8	111	160	217
95	219.4	119.0	1.14	4.56	10.2	18.2	41.0	72.8	114	164	223
100	230.9	122.0	1.17	4.67	10.5	18.7	42.1	74.7	117	168	229
105	242.4	125.0	1.20	4.79	10.8	19.2	43.1	76.5	120	172	234
110	254.0	128.0	1.23	4.90	11.0	19.6	44.1	78.4	122	176	240
115	265.5	130.9	1.25	5.01	11.2	20.0	45.1	80.1	125	180	245
120	277.1	133.7	1.28	5.12	11.5	20.5	46.0	81.6	128	184	251
125	288.6	136.4	1.31	5.22	11.7	20.9	47.0	83.5	130	188	256
130	300.2	139.1	1.33	5.33	12.0	21.3	48.0	85.2	133	192	261
135	311.7	141.8	1.36	5.43	12.2	21.7	48.9	86.7	136	195	266
140	323.3	144.3	1.38	5.53	12.4	22.1	49.8	88.4	138	199	271
145	334.8	146.9	1.41	5.62	12.6	22.5	50.6	91.5	140	202	275
150	346.4	149.5	1.43	5.72	12.9	22.9	51.5	90.8	143	206	280
175	404.1	161.4	1.55	6.18	13.9	24.7	55.6	106	154	222	302
200	461.9	172.6	1.65	6.61	14.8	26.4	59.5	116	165	238	325

HEAD		Velocity of Discharge in Feet per Second	DIAMETER OF NOZZLES IN INCHES								
Pounds	Feet		1	1 1/3	1 1/4	1 3/8	1 1/2	1 3/4	2	2 1/4	2 1/2
10	23.1	38.6	94.5	120	148	179	213	289	378	479	591
15	34.6	47.25	116.0	147	181	219	280	354	463	585	723
20	46.2	54.65	134	169	209	253	301	409	535	676	835
25	57.7	61.0	149	189	234	283	336	458	598	756	934
30	69.3	68.85	164	207	256	309	368	501	655	828	1023
35	80.8	72.2	177	224	277	334	398	541	708	895	1106
40	92.4	77.2	188	239	296	357	425	578	756	957	1182
45	103.9	81.8	200	253	313	379	451	613	801	1015	1252
50	115.5	86.25	211	267	330	399	475	647	845	1070	1320
55	127.0	90.4	221	280	346	418	498	678	886	1121	1385
60	138.6	94.5	231	293	362	438	521	708	926	1172	1447
65	150.1	98.3	241	305	376	455	542	737	964	1220	1506
70	161.7	102.1	250	317	391	473	563	765	1001	1267	1565
75	173.2	105.7	259	327	404	489	582	792	1037	1310	1619
80	184.8	109.1	267	338	418	505	602	818	1100	1354	1672
85	196.3	112.5	276	349	431	521	620	844	1103	1395	1723
90	207.9	115.8	284	359	443	536	638	868	1136	1436	1773
95	219.4	119.0	292	369	455	551	656	892	1168	1476	1824
100	230.9	122.0	299	378	467	565	672	915	1196	1512	1870
105	242.4	125.0	306	388	479	579	689	937	1226	1550	1916
110	254.0	128.0	314	397	490	583	705	960	1255	1588	1961
115	265.5	130.9	320	406	501	606	720	980	1282	1621	2005
120	277.1	133.7	327	414	512	619	736	1002	1310	1659	2050
125	288.6	136.4	334	423	522	632	751	1022	1338	1690	2090
130	300.2	139.1	341	432	533	645	767	1043	1365	1726	2132
135	311.7	141.8	347	439	543	655	780	1063	1390	1759	2173
140	323.3	144.3	354	448	553	663	795	1082	1415	1790	2212
145	334.8	146.9	360	455	562	680	809	1100	1440	1820	2250
150	346.4	149.5	366	463	572	692	824	1120	1466	1853	2290
175	404.1	161.4	395	500	618	747	890	1210	1582	2000	2473
200	461.9	172.6	423	535	660	799	950	1294	1691	2140	2645

NOTE: The actual quantities will vary from these figures, the amount of variation depending upon the shape of the nozzle and the size of pipe at the point where the pressure is determined. With smooth taper nozzles, the actual discharge is about 94 percent of the figures given in the above tables.



WHERE TO USE SELF PRIMING PUMPS

CONSTRUCTION USES

Pump Out –

1. Small excavations
2. Foundations
3. Manholes
4. Several well points
5. Strip mines
6. Flood water
7. Sewage by-passing

Fill –

1. Water wagons

General Uses –

1. Wash down equipment
2. Barge cleaning
3. Marinas

FARM USES

Irrigation Uses –

1. Truck farms
2. Fill stock tanks
3. Wash down barn areas
4. Transfer liquid manures
5. Washing of equipment
6. Pump out flood water
7. Standby fire protection
8. Water transfer at fish farms